



SD1405

RF & MICROWAVE TRANSISTORS HF SSB APPLICATIONS

- 30 MHz
- 12.5 VOLTS
- COMMON EMITTER
- IMD 32 dB
- GOLD METALLIZATION
- $P_{OUT} = 75 \text{ W MIN. WITH } 13 \text{ dB GAIN}$

DESCRIPTION

The SD1405 is a 12.5 V Class C epitaxial silicon NPN planar transistor designed primarily for HF communications. This device utilizes diffused emitter resistors to achieve infinite VSWR under rated operating conditions.

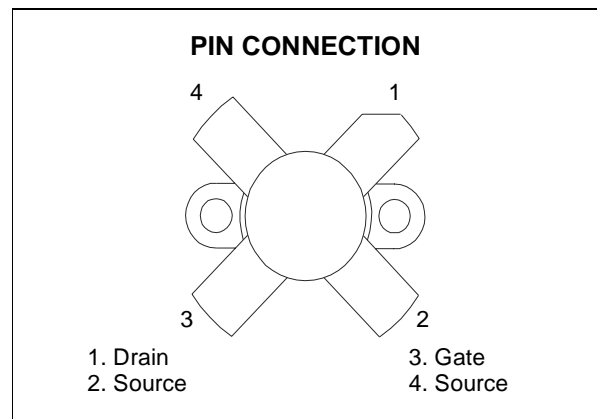
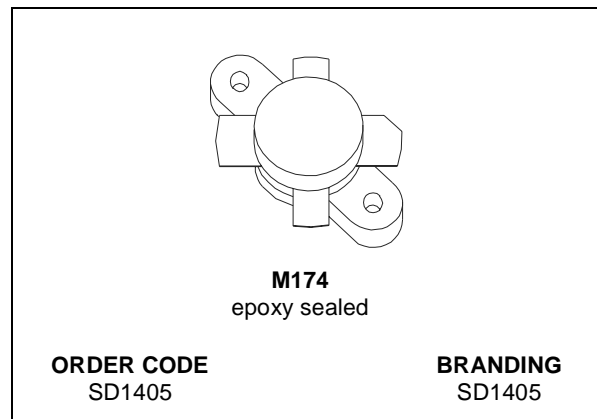

ABSOLUTE MAXIMUM RATINGS ($T_{CASE} = 25 \text{ }^{\circ}\text{C}$)

Symbol	Parameter	Value	Unit
V_{CBO}	Collector-Base Voltage	36	V
V_{CEO}	Collector-Emitter Voltage	18	V
V_{EBO}	Emitter-Base Voltage	4.0	V
I_C	Device Current	20	A
P_{DISS}	Power Dissipation	270	W
T_j	Max. Operating Junction Temperature	+200	$^{\circ}\text{C}$
T_{STG}	Storage Temperature	-65 to +150	$^{\circ}\text{C}$

THERMAL DATA

$R_{th(j-c)}$	Junction -Case Thermal Resistance	0.65	$^{\circ}\text{C/W}$
---------------	-----------------------------------	------	----------------------

SD1405

ELECTRICAL SPECIFICATION (T_{CASE} = 25 °C)

STATIC

Symbol	Test Conditions	Min.	Typ.	Max.	Unit
BV _{CBO}	I _C = 50 mA I _E = 0 mA	36			V
BV _{CES}	I _C = 100 mA V _{BE} = 0 V	36			V
BV _{CEO}	I _C = 100 mA I _B = 0 mA	18			V
BV _{EBO}	I _E = 10 mA I _C = 0 mA	4.0			V
I _{CES}	V _{CE} = 15 V I _E = 0 mA			2	mA
h _{FE}	V _{CE} = 5 V I _C = 5 A	20		300	

DYNAMIC

Symbol	Test Conditions	Min.	Typ.	Max.	Unit
P _{OUT}	f = 30 MHz P _{IN} = 3.8 W V _{CE} = 12.5 V	75			W
G _P	f = 30 MHz P _{IN} = 3.8 W V _{CE} = 12.5 V	13			dB
IMD*	f = 30 MHz V _{CE} = 12.5 V I _{CQ} = 100 mA	32			dB
C _{OB}	f = 1 MHz V _{CB} = 12 V		350		pF

* P_{OUT} = 60 W PEP, f₀ = 30 + 30.001 MHz

TYPICAL PERFORMANCE

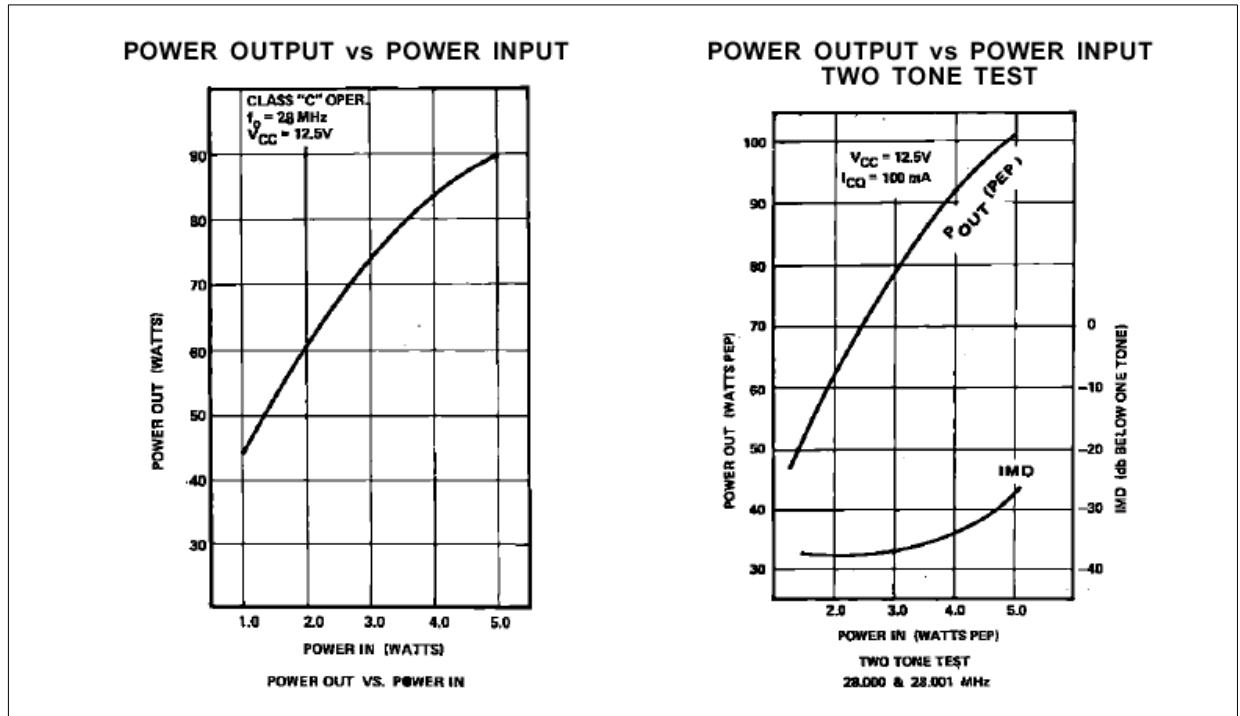

IMPEDANCE DATA

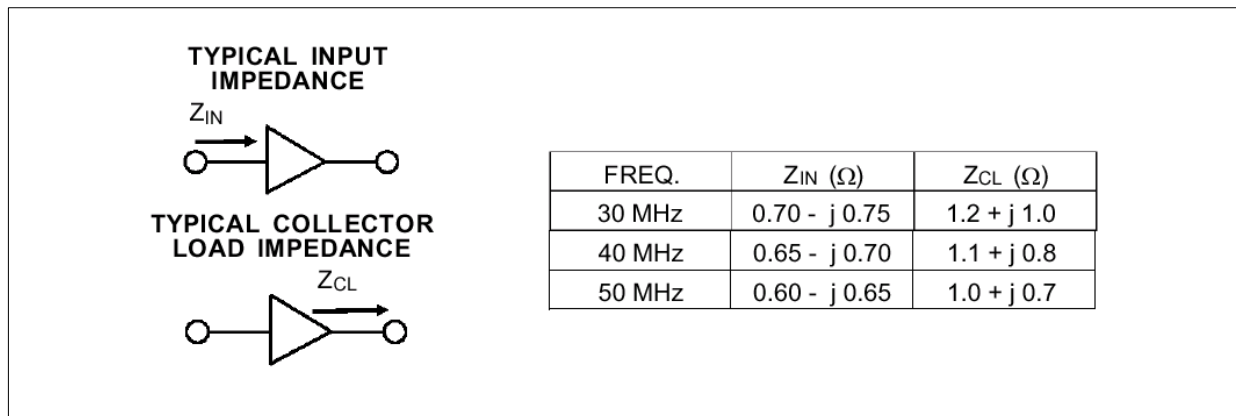

TEST CIRCUIT

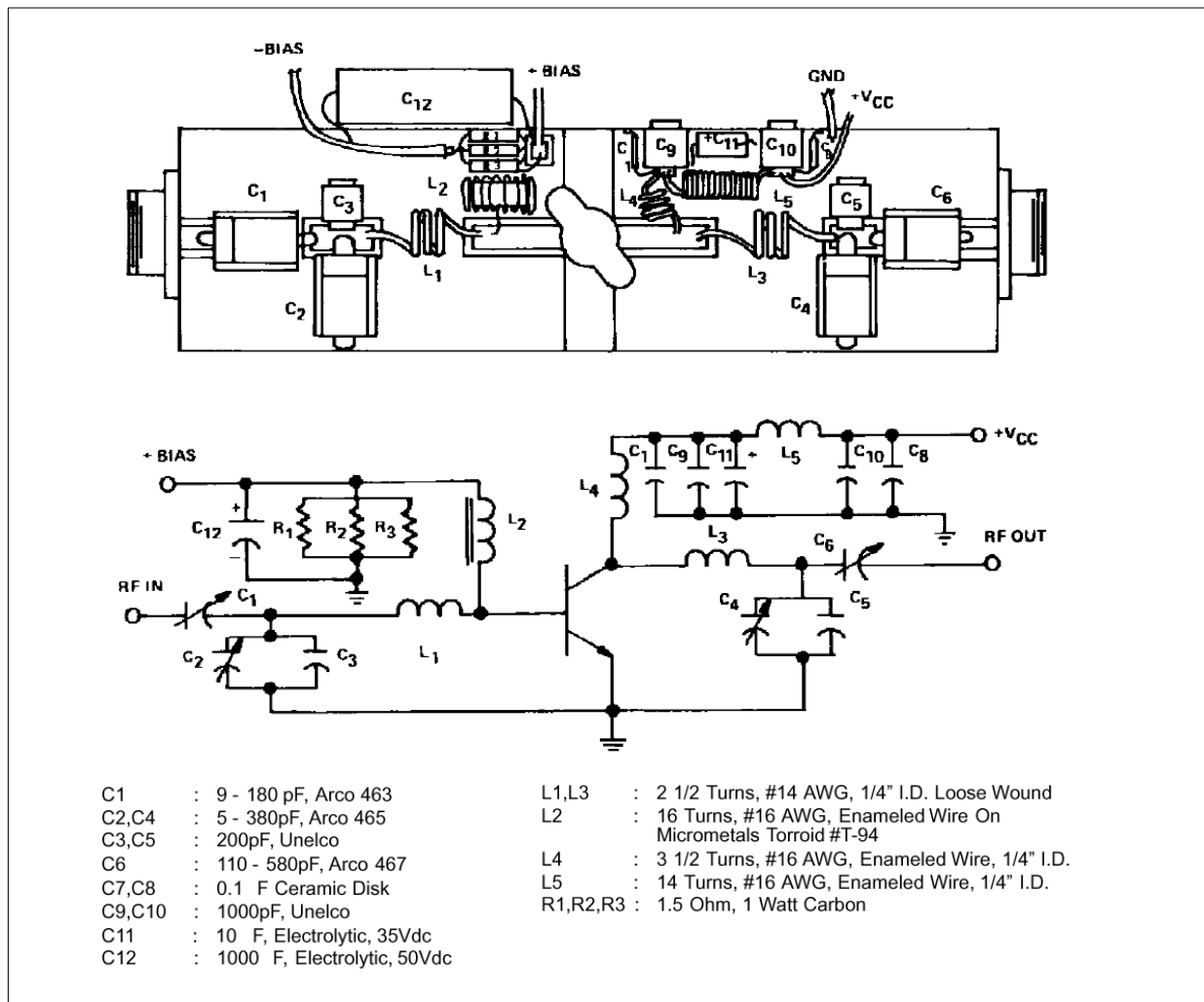

M174 (.500 DIA 4/L N/HERM W/FLG) MECHANICAL DATA

DIM.	mm			Inch		
	MIN.	TYP.	MAX	MIN.	TYP.	MAX
A	5.56		5.584	0.219		0.230
B		3.18			0.125	
C	6.22		6.48	0.245		0.255
D	18.28		18.54	0.720		0.730
E		3.18			0.125	
F	24.64		24.89	0.970		0.980
G	12.57		12.83	0.495		0.505
H	0.08		0.18	0.003		0.007
I	2.11		3.00	0.083		0.118
J	3.81		4.45	0.150		0.175
K			7.11			0.280
L	25.53		26.67	1.005		1.050
M	3.05		3.30	0.120		0.130

